

ROAD TRAFFIC ACT
(CHAPTER 276, SECTION 140)

ROAD TRAFFIC (BICYCLE CROSSING) RULES

ARRANGEMENT OF RULES

Rule

1. Citation
 2. Definitions
 3. Cyclists, PMD riders and pedestrians must use crossings
 4. Use of bicycle crossing
 5. Precedence at controlled crossings
 6. Prohibition against the waiting of vehicles and cyclists, etc.
 7. [Deleted]
The Schedule
-

[15th April 1996]

Citation

1. These Rules may be cited as the Road Traffic (Bicycle Crossing) Rules.

Definitions

2. In these Rules, unless the context otherwise requires —

“bicycle” has the meaning given by the Act, and includes a vehicle that has 3 wheels, has pedals, and is built to be propelled solely by human power and to transport people only (with or without carry-on baggage);

“bicycle crossing” means any part of a road, subway or bridge established for the use of a cyclist or pedestrian crossing the road, and indicated as such by traffic signs, signals and road markings as shown in any of the diagrams in Part I or II of the Schedule;

“cyclist” means an individual who is riding a bicycle or power-assisted bicycle, but excludes an individual who is

walking beside and pushing a bicycle or power-assisted bicycle;

“mobility scooter” and “wheeled toy” have the meanings given by section 2(1) of the Active Mobility Act 2017 (Act 3 of 2017);

“pedestrian” means —

- (a) an individual walking, with or without animals;
- (b) an individual in a non-motorised wheelchair;
- (c) an individual driving a motorised wheelchair or riding a mobility scooter;
- (d) an individual travelling on inline skates, roller-skates or a wheeled toy;
- (e) an individual pushing a pram, stroller or trolley, or a motorised or non-motorised wheelchair; or
- (f) an individual walking beside and pushing a bicycle, power-assisted bicycle, personal mobility device or any other vehicle;

“PMD” means a personal mobility device;

“PMD rider” means an individual who is riding a personal mobility device on a road as permitted by section 5A(2) of the Act, but excludes an individual who is walking beside and pushing a PMD.

[S 277/2018 wef 05/05/2018]

Cyclists, PMD riders and pedestrians must use crossings

3.—(1) Any cyclist, PMD rider or pedestrian who is within 50 metres of either side of a bicycle crossing, or within such shorter distances, as indicated by traffic signs, shall make use of the bicycle crossing for the purpose of crossing the road, subway or bridge, as the case may be.

[S 277/2018 wef 05/05/2018]

(2) The traffic signs, as shown in the diagrams in Part II of the Schedule, indicating the limits of 50 metres or such shorter distances shall be prominently displayed.

[S 277/2018 wef 05/05/2018]

Use of bicycle crossing

4.—(1) Every cyclist or PMD rider shall, before entering a bicycle crossing, stop his bicycle, power-assisted bicycle or personal mobility device, as the case may be, at the crossing road sign as indicated by the diagram in Part III of the Schedule.

[S 277/2018 wef 05/05/2018]

(2) Where a bicycle crossing is designated by a signalised traffic sign, the cyclist, PMD rider or pedestrian shall only cross when the green bicycle in the signalised traffic sign is illuminated.

[S 277/2018 wef 05/05/2018]

(3) [*Deleted by S 277/2018 wef 05/05/2018*]

(4) No cyclist, PMD rider or pedestrian shall —

(a) enter a bicycle crossing when the green bicycle in the signalised traffic sign is flashing as the red bicycle light is about to be illuminated; or

(b) use a bicycle crossing when the red bicycle in the signalised traffic sign is illuminated.

[S 277/2018 wef 05/05/2018]

Precedence at controlled crossings

5. Every cyclist, PMD rider or pedestrian who has entered a bicycle crossing when permitted to do so by a police officer controlling the traffic or by light signals shall have free and uninterrupted passage over the crossing by all drivers of vehicles who are approaching the crossing notwithstanding that the drivers may receive a signal to proceed either from the light signals or the police officer, as the case may be.

[S 277/2018 wef 05/05/2018]

Prohibition against the waiting of vehicles and cyclists, etc.

6.—(1) The driver of a vehicle shall not cause the vehicle or any part thereof to stop within the limits of a bicycle crossing unless either he is prevented from proceeding by circumstances beyond his control or it is necessary for him to stop in order to avoid an accident.

(2) No cyclist, PMD rider or pedestrian shall remain on the road, subway or bridge within the limits of a bicycle crossing longer than it is necessary for the purpose of passing over the crossing with reasonable despatch.

[S 277/2018 wef 05/05/2018]

[S 277/2018 wef 05/05/2018]

7. [Deleted by S 277/2018 wef 05/05/2018]

THE SCHEDULE

Rule 2

PART I

DIAGRAM 1

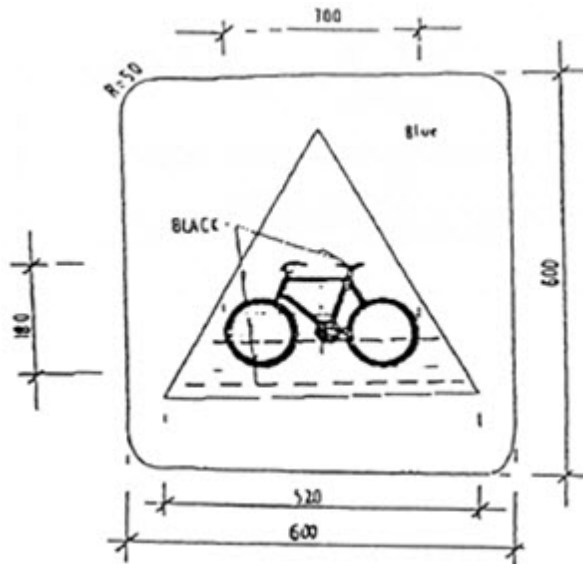

TRAFFIC SIGN INDICATING BICYCLE CROSSING

THE SCHEDULE — continued

DIAGRAM 1A

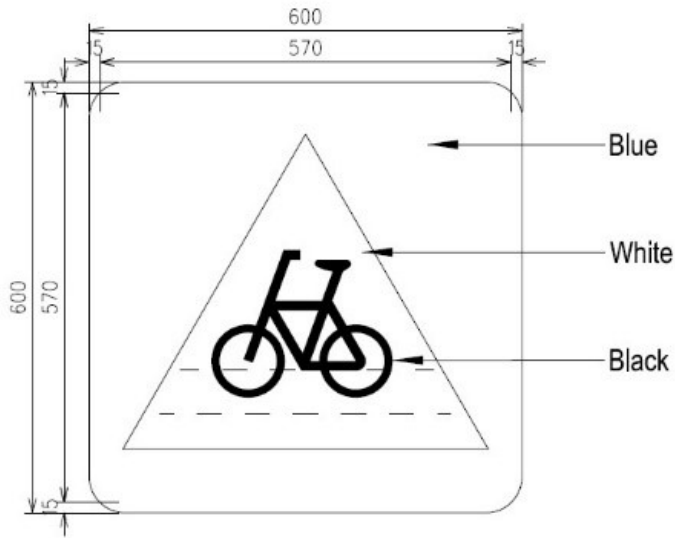

TRAFFIC SIGN INDICATING BICYCLE CROSSING

DIAGRAM 2

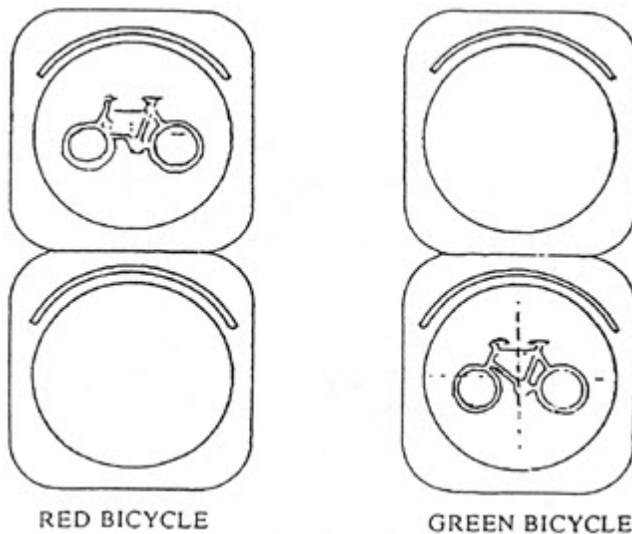

THE SCHEDULE — *continued*

RED BICYCLE/GREEN BICYCLE TRAFFIC SIGNALS
INDICATING BICYCLE CROSSING

[S 277/2018 wef 05/05/2018]

Rule 3

PART II

DIAGRAM 1

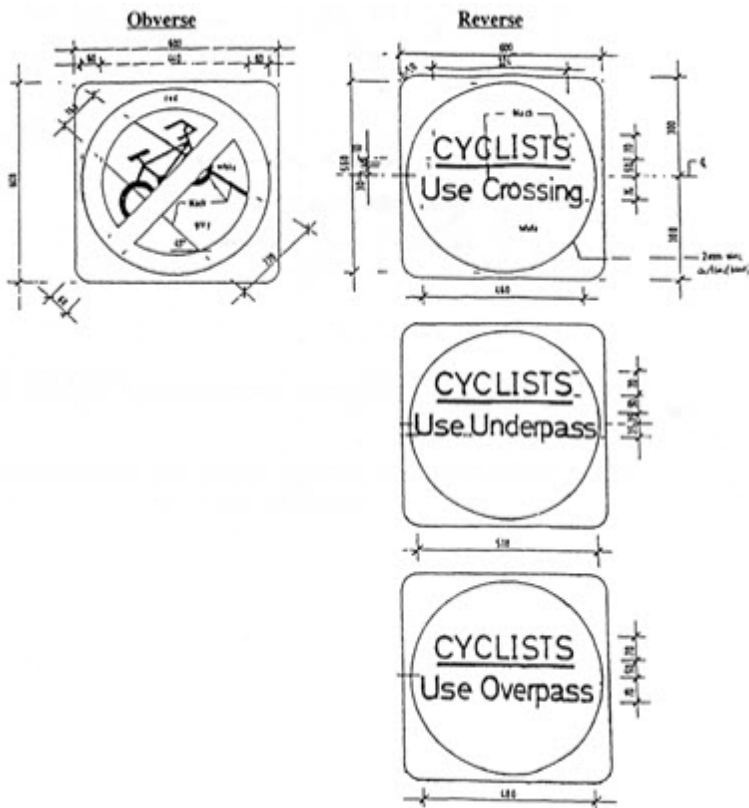

whichever is appropriate.

BICYCLE CROSSING PROHIBITION SIGN

THE SCHEDULE — *continued*

DIAGRAM 1A

Obverse

Reverse

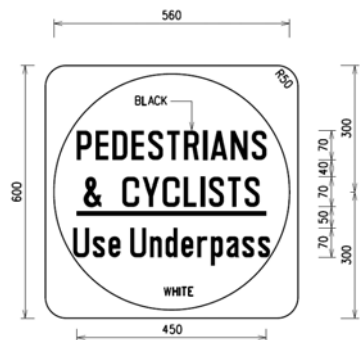
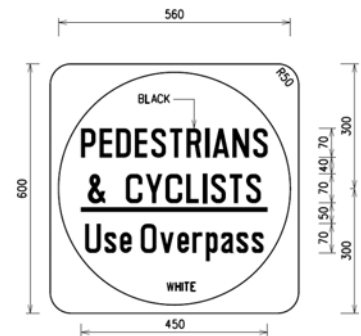
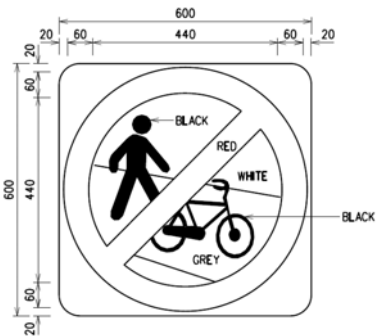
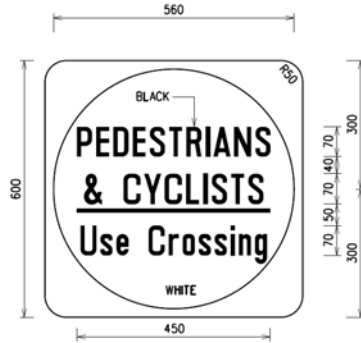
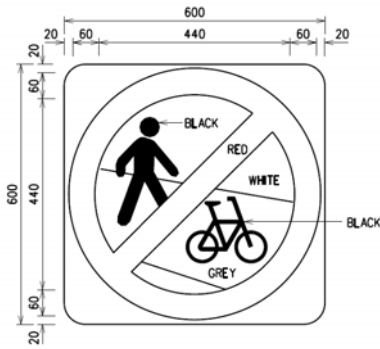

whichever is appropriate.

THE SCHEDULE — continued

DIAGRAM 2(a)



DIAGRAM 2(b)



DIRECTIONAL ARROWS

These supplementary signs, when used in conjunction with prohibitory or restrictive signs, indicate the section of the road, subway or bridge, as the case may be, to which the prohibition or restriction applies.

[S 277/2018 wef 05/05/2018]

Rule 4

PART III

DIAGRAM 1

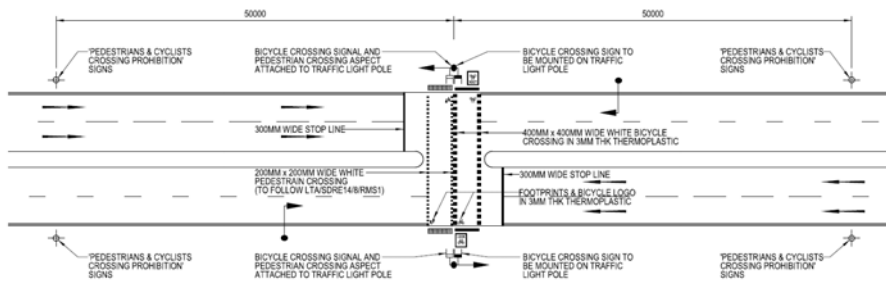

THE SCHEDULE — *continued*

[S 277/2018 wef 05/05/2018]

[G.N. No. S 163/96]

LEGISLATIVE HISTORY
ROAD TRAFFIC (BICYCLE CROSSING) RULES
(CHAPTER 276, R 36)

This Legislative History is provided for the convenience of users of the Road Traffic (Bicycle Crossing) Rules. It is not part of these Rules.

1. G. N. No. S 163/1996 — Road Traffic (Bicycle Crossing) Rules 1996

Date of commencement : 15 April 1996

2. 1997 Revised Edition — Road Traffic (Bicycle Crossing) Rules

Date of operation : 15 June 1997

3. G.N. No. S 277/2018 — Road Traffic (Bicycle Crossing) (Amendment) Rules 2018

Date of commencement : 5 May 2018